

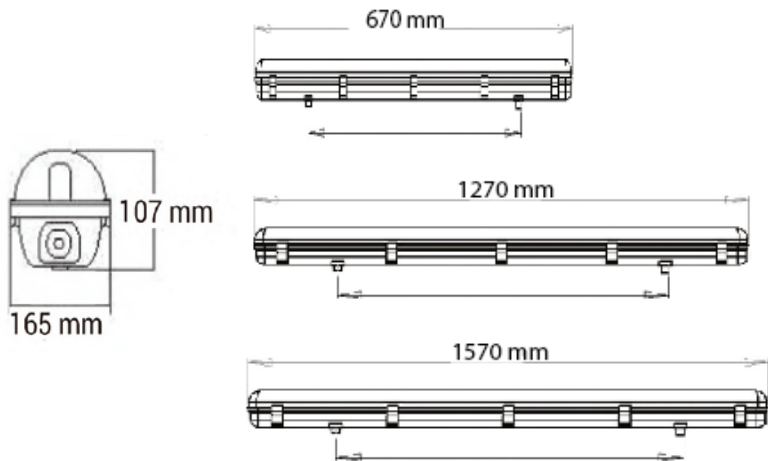

greenlux
cost reduction LED lighting

Chamber TUBE Series **Twin** LED T8 Parking Fixture

Available in Common, Sensor, Emergency, Sensor & Emergency



- Replaces traditional T8 Fixture
- Available in Common, Sensor, Emergency and Emergency/Sensor
- Easy installation and maintenance
 - Diffuser permanently attached by 2 clips
 - 2 x 6mm terminal blocks, middle and ends
 - 2.5A wire connecting all two terminal blocks
 - Gear tray restraints for easy maintenance
 - Ceiling, wall or suspension mounting with optional mounting brackets
 - Multiple drill-out conduit entry points, middle and ends
- High light output 1900/3450/4750lm
- High quality LED Chipset SMD 2835
- Polycarbonate body and diffuser, vandal resistant
- Stainless steel clips, tamper resistant
- IP65 Rated
- 5 Years Warranty
- Applications include carparks, hallways, utility areas, food preparation areas, including outdoor locations

Dimensions

Product Dimensions (mm)	670*165*107	(LxWxH)
	1270*165*107	(LxWxH)
	1570*165*107	(LxWxH)

Housing Materials	ABS Base & PC Diffuser
-------------------	------------------------

Certification and Safety

Certifications	IP65, CE, RoHS, SAA, RCM
Environment	Indoor & Outdoor Location
Warranty	5 years





greenlux
cost reduction LED lighting

Chamber TUBE Series **Twin** LED T8 Parking Fixture

Specifications

Colour Range	3000-6000k
Power Consumption	20W/36W/50W
Lumens	1900/3450/4750lm
Chipset	LED SMD 2835
Input Voltage	100-240V AC
Driver Output Voltage	DC 36V
Driver Output Current	460mA~510mA 950mA~1050mA 1050mA~1250mA
Beam angle	110°
Ra	80
PF	>0.9
IP Rating	IP65

Emergency

Type	Self-test (Monthly)
Battery (Rechargeable)	9.6V 3.2AH Ni-MH
Emergency Standard	AS 2293
Emergency Output	30% nominal power
Emergency Duration	>90 Minutes
Charge Time	<12 Hours
LED indication	Red: charging; Green: fully charged; Yellow: battery fault or disconnected
Test button	AC power on: Push and hold the button to enter emergency mode; release button to come back AC power mode



Microwave Sensor

Sensor Range	180 degree; 1 - 8M (adjustable)
Sensing Interval	10s to 5min max (adjustable)
Sensing interval output	20% light output at standby
Detection Angle	360 degree
Input Voltage	12V DC
Output Power	5V DC
HF System	5.8Hz+/-75MHz CW Radar ISM band



greenlux
cost reduction LED lighting

Chamber TUBE Series **Twin** LED T8 Parking Fixture

Photometrics

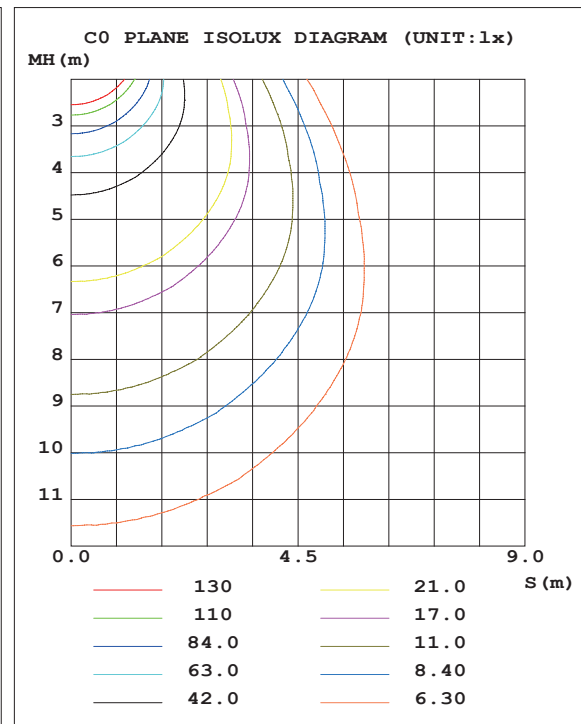
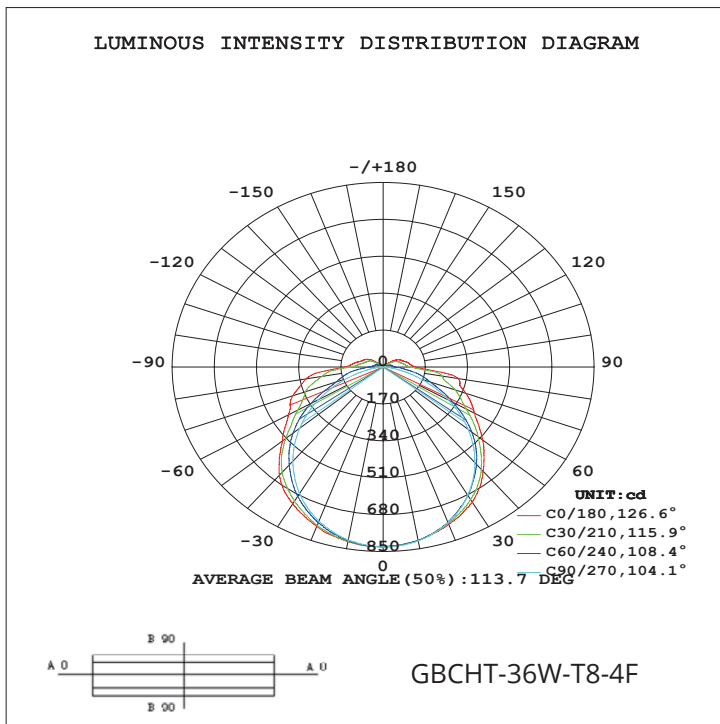

Model	Power	Size	Voltage	LED	CCT	Lumens	Function
GBCHT-20W-T8-2F	20W	670x165x107mm	AC 100-240V	2835 LED	3000-6000K	1900lms	Common, Sensor, Emergency, Sensor & Emergency
GBCHT-36W-T8-4F	36W	1270x165x107mm	AC 100-240V	2835 LED	3000-6000K	3450lms	Common, Sensor, Emergency, Sensor & Emergency
GBCHT-50W-T8-5F	50W	1570x165x107mm	AC 100-240V	2835 LED	3000-6000K	4750lms	Common, Sensor, Emergency, Sensor & Emergency

