



# Chain GAS35 D1512

LED Linear Inward Light



**greenlux**  
cost reduction LED lighting

# Chain GAS35 D1512

## LED Linear **Inward** Light

GREENLUX CURVE LIGHTING WITH LIMITLESSNESS - GAS35 stylish lighting system, through the sublimation from straight line to curve, transformation from 2D to 3D, linear lighting is brought with a brand -new revolutionary experience. The basic modules can constitute standard circular luminaires with the diameter of 0.8m/1.5m/3.0m for independent application. Multiple light emitting directions are optional: lighting downward, lighting outward and lighting inward. The light emitting modes are optional according to the scenes as well, so as to create different atmospheres.

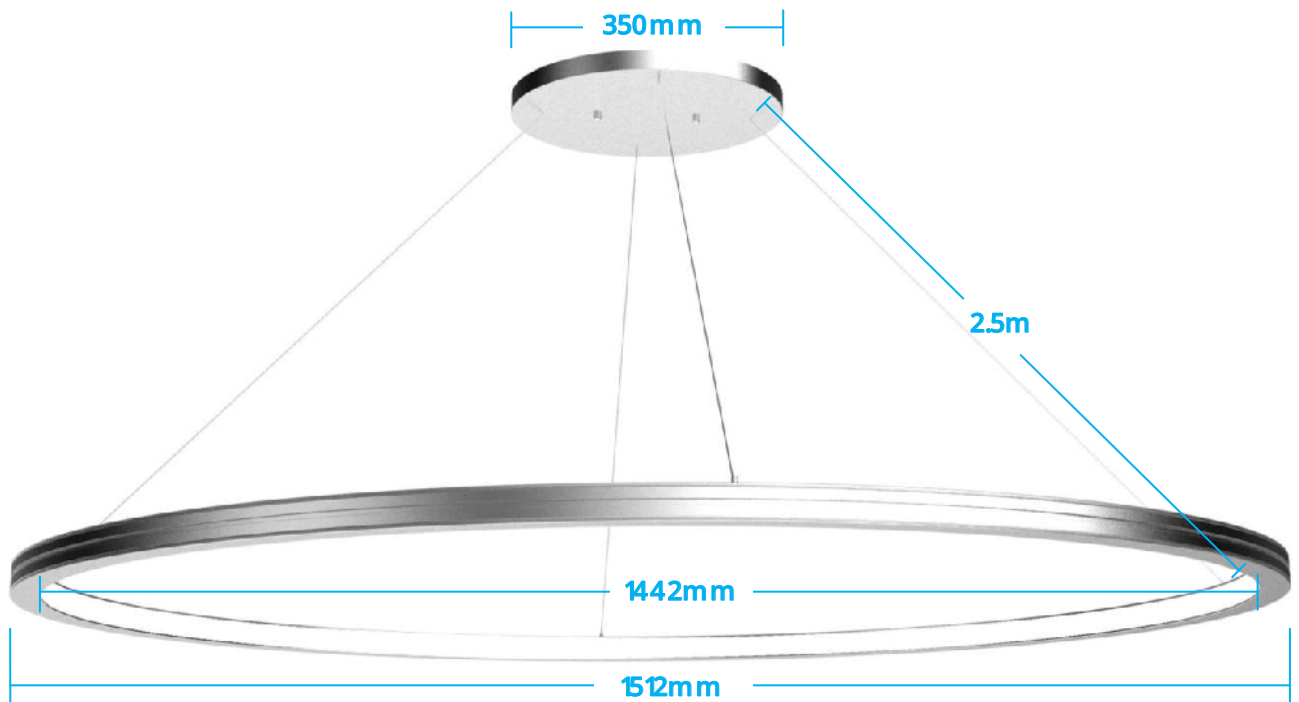

- $\Phi$  1.5M, circular luminaires of lighting inward;
- High quality surface treatment, three optional colors of black, white and silver;
- Adopt silicone flexible diffuser, producing homogenous & soft lighting;
- Pendant cable and wire in one, beautiful overall effect;
- Two installation ways: pendant and surface mounted.

# Chain GAS35 D1512

## LED Linear Inward Light

### Optical & electronic data

Model	Size	CCT	Flux (lm)	CRI	Beam angle	Input voltage	Dimming	PF	Power (w)
GCCHA-GAS35-D1512-105W (including power supply)	Φ1500mm, lighting inward, 360° luminaires	1900K	1720LM	>80 >90	120°	100~265VAC 50/60Hz	Non-dimmable Dimmable (options)	>0.9	105W
		2300K	1810LM						
		2700K	1910LM						
		3000K	2010LM						
		3500K	2120LM						
		4000K	2230LM						
		5000K	2340LM						
GCCHA-GAS35-D1512-90W (no power supply)	Φ1500mm, lighting inward, 360° luminaires	1900K	1720LM	>80 >90	120°	DC24V	/	/	90W
		2300K	1810LM						
		2700K	1910LM						
		3000K	2010LM						
		3500K	2120LM						
		4000K	2230LM						
		5000K	2340LM						
6000K	2230LM								

Remark :

- 1、 the tolerance of output data can be vary up to 10%;
- 2、 the output data is typical value;

Luminaire of 1.5m diameter and lighting inward matched with flexible diffuser

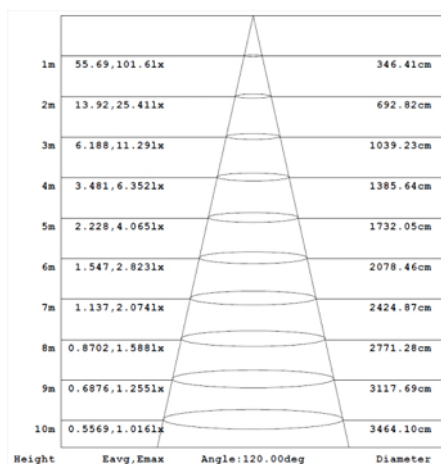

AAI FIGURE

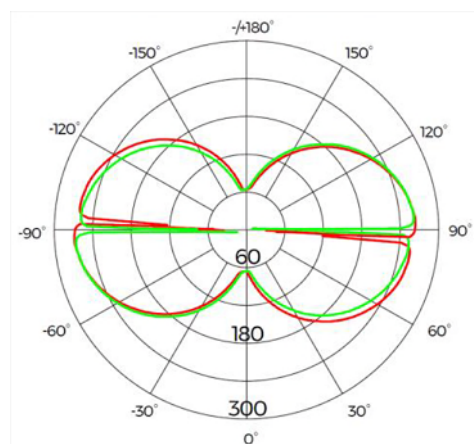

Luminous intensity distribution

# Chain GAS35 D1512

## LED Linear **Inward** Light

### Packing

The whole package

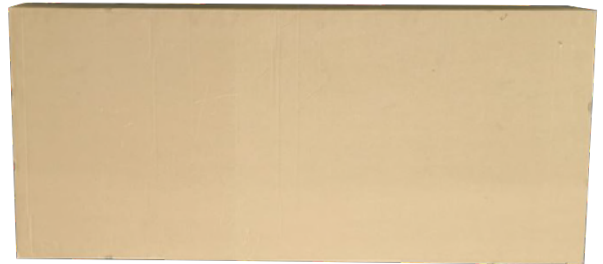

Model	Type	Demension (individual package )	Pcs/bundle	NW (Kg)	GW (Kg)	Demension (whole package )	CBM (m³)
GCCHA-GAS35-D1512-105W (pendant / including power supply)	Box	1198*546*110mm	1	5.42	7.58	1198*546*110mm	0.072
GCCHA-GAS35-D1512-90W (pendant / no power supply)				5.25	7.41		
GCCHA-GAS35-D1512-105W (surface mounted / including power supply)				4.42	7.48		
GCCHA-GAS35-D1512-90W (surface mounted / no power supply)				4.25	7.31		